



**IEA Implementing Agreement on  
Electricity Networks Analysis, Research and Development (ENARD)**

*Annex I Workshop Profile*

*“DG System Integration and New Business Models”*

**Annex I: Information Collation and Dissemination**

**Annex I Workshop held Arsenal Research, Vienna, Austria,  
20<sup>th</sup> - 21<sup>st</sup> March 2007**

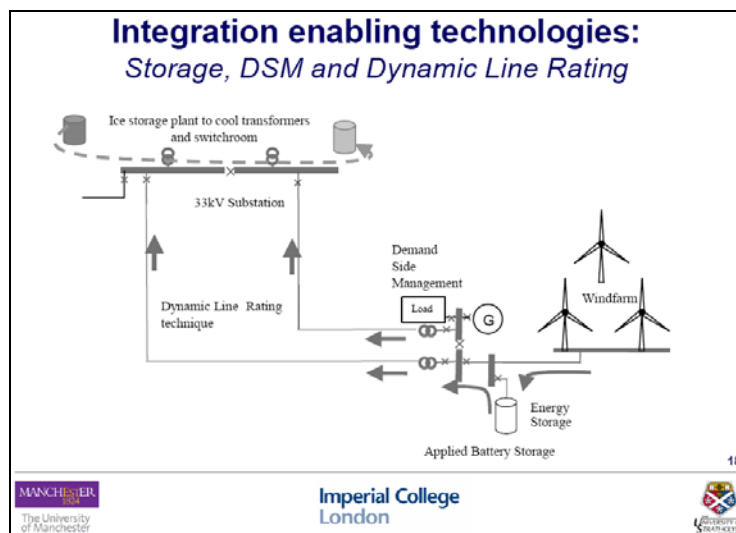

[from the presentation given by C Ramsay, G Strbac,  
DTI Centre for Distributed Generation & Sustainable Electrical Energy, UK]

**Summary:**

*The workshop was convened to help develop the structure and content of a dedicated new ENARD work programme activity (Annex) in the area of “DG system integration and new business models”.*

*The workshop drew the support of 19 participants from 10 countries and comprised a series of expert presentations, dedicated working groups and open discussion and dialogue.*

*Consensus was reached in relation to the development of a dedicated ENARD Annex II work programme aimed at the development of guidelines and benchmarks relating to all aspects DG system integration. The workshop concluded by reaching agreement on the anticipated scope of the new Annex, its desired deliverables and forward development.*

This workshop forms one of a series of ENARD Annex I workshops organised and delivered by EA Technology in its capacity as ENARD Annex I Operating Agent



# Workshop profile

## 1 Introduction

The workshop was convened as the second in the series of topical experts' meetings and workshops of the International Energy Agency (IEA) Implementing Agreement on Electricity Networks Analysis, Research and Development (ENARD). ENARD has been developed in order to address a wide range of issues associated with electricity transmission and distribution (T&D) systems. Annex I serves as the central information collation and dissemination Annex and also contributes to the definition of future priorities for the Implementing Agreement as a whole.

Annex I is essentially led by a series of topical experts' meetings and workshops, each addressing particular areas of interest that act as the foundation for the development of future collaborative research and development (R&D) Annexes. Further details may be found on the ENARD web-site at [www.iea-enard.org](http://www.iea-enard.org) or e:mail [enquiries@iea-enard.org](mailto:enquiries@iea-enard.org).

## 2 Workshop Aim and Objectives

The workshop was convened with a view to helping define the work programme priorities in a potential Annex on "DG System Integration and New Business Models" aiming to identify:

- Key challenges;
- Information requirements;
- Opportunities for collaborative R&D;
- Complementarities with other initiatives and programmes; and
- The associated opportunity to develop a structured follow-on (R&D) Annex.

The workshop terms-of-reference included both technical solutions, for the network integration of DG, and also the complementary business models to fully recognise and exploit the potential added value benefits of DG.

## 3 Workshop Structure and Programme

The workshop was structured to comprise a series of expert presentations, followed by break-out into a series of working groups. The workshop re-convened for working groups to report and for open discussion and agreement on the principal workshop outcomes and conclusions.

Philip Baker, Chair of the ENARD ExCo (DTI, UK) opened the workshop with Michael Hübner (BMVIT,

Austria) welcoming participants before handing over the Chair for the remainder of the workshop to John Baker, ENARD Annex I Operating Agent (EA Technology, UK).

## 4 Expert Presentations

**The market integration of renewables** (Mikael Togeby, Ea Energy Analyses, Denmark. Operating Agent, IEA Implementing Agreement on Renewable Energy Technology Deployment (RETDD))

Mr Togeby's presentation opened by introducing Ea Energy Analyses, the Operating Agent for the IEA Renewable Energy Technology Deployment (RETDD) Implementing Agreement, which focuses on the various cross-cutting barriers to the wider uptake of renewables. Case study examples of the operation of the large scale penetration of wind in the Danish market were described, highlighting some of the challenges associated with the intermittency of the resource and its prediction, relative to the prevalent electricity markets.

Mr Togeby noted that, whilst the market mechanisms may be well suited to conventional generation, including large coal fired plant and large scale hydro-electric schemes, they are often far less suited to an intermittent resource such as wind, which can only be reliably predicted on relatively short timescales (eg on an hour ahead basis).

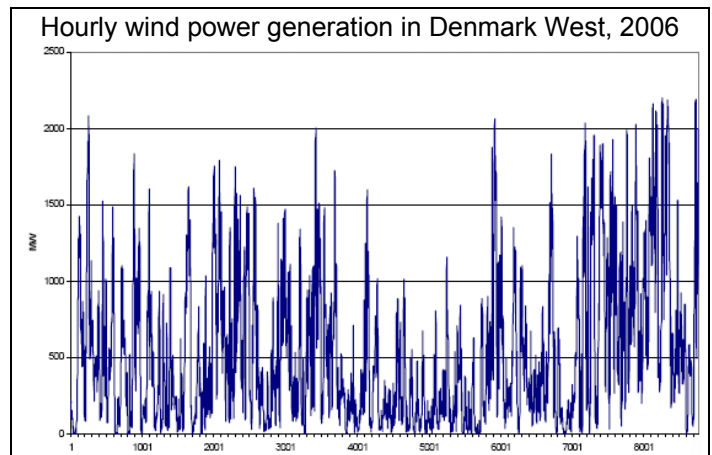

[from the presentation given by M Togeby, Ea Energy Analyses, Denmark. Operating Agent, IEA Implementing Agreement on Renewable Energy Technology Deployment]

Examples of four different types of electricity market mechanisms were then described, namely near real time markets, imbalances, the provision of demand response as a regulating mechanism and, finally, nodal pricing as a mechanism to achieve optimal use of a constrained electricity network.

**Technology requirements for DG integration** (Charlotte Ramsay, DTI Centre for Distributed Generation and Sustainable Electrical Energy, Imperial College, London, UK)

Mrs Ramsay described the establishment of the DTI Centre for Distributed Generation and Sustainable Electrical Energy, which performs fundamental research in support of UK energy policy goals. She noted the need to expedite the transition from the connection of DG through

to its integration and commented on the requirement for further increases in conventional generation capacity coincidental with increases in DG. Mrs Ramsay contrasted two fundamentally different approaches to the provision of network performance:

- Today's passive networks (performance via design measures, plant ratings etc);
- Tomorrow's active networks (performance via advanced network control measures and the greater role of DG in system support and network development/replacement).

Key enabling technologies in support of the greater integration of DG were noted as:

- Energy storage;
- Smart metering and demand side management;
- Dynamic ratings;
- Network automation;
- Flexible AC transmission systems (FACTS);
- Current limiters;
- Solid state substations.

In conclusion, she noted that the actual and projected greater uptake of DG is changing the overall approach to system planning and operation requiring both technological innovation and also fundamental changes in the prevalent commercial and regulatory frameworks.

### Modelling tools for distributed generation

(Professor Geza Joos, McGill University, Montreal, Canada, on behalf of Natural Resources Canada (NRCan))

Professor Joos proposed the development of a guide for implementing DG, supported by a work programme to include identifying gaps or barriers to wider deployment of DG, documentation and comparison of international case study experience and a series of regional workshops. The target audience for the guide would be distribution utilities, manufacturers and installers. Consistent with their goal to incorporate 10% of wind generation into the Canadian electricity system, NRCan sees a clear role for ENARD in developing such a guide.

Professor Joos described some of NRCan's technological and modelling activities in support of the wider uptake of DG, and noted the requirement in terms of:

- Renewables integration;
- An increasingly ageing infrastructure;
- Energy efficiency;
- Intelligent networks;
- Customer requirements for greater reliability;
- De-regulation;
- New distribution system architectures and operating strategies.

He reviewed a range of modelling tools and described a Canadian utility survey highlighting key requirements:

- Short circuit current distribution between distributed generators and the network;
- Protective device co-ordination;
- System planning;
- Load forecasting, including normalization for weather effects;
- Dynamic stability of synchronous generators;
- Compatibility with existing records and documents.

### Policy framework and business models

(Seppo Kärkkäinen, VTT, Finland, Operating Agent, Task XVII, IEA Implementing Agreement on Demand Side Management (DSM))

Mr Kärkkäinen's presentation was drawn principally from two ongoing European Commission projects, EU-DEEP and DG-GRID. He noted that the policy framework for DG was driven at the top level by various European Union and national energy policy objectives, including those related to developing electricity markets. He also noted the close relationship between policy and regulatory aspects.

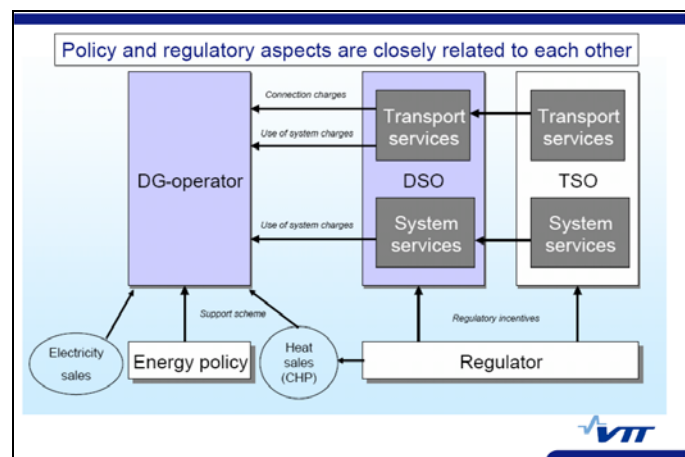

[from the presentation given by S Kärkkäinen, VTT, Finland]

The DG-GRID project had conducted an extensive survey of the barriers to DG, the most significant being: (i) absence of incentives for distribution network operators; (ii) connection charges. Exemptions in the unbundling of electricity markets were also evident.

Mr Kärkkäinen described the different business models available for DG, and the potential role for aggregators as a major new player in the market. He noted that the EU-DEEP project is studying the potential role of such aggregators in greater detail and cited various examples, including renewables balancing and local markets.

Mr Kärkkäinen concluded his presentation by describing the development and rationale behind the newly started IEA Implementing Agreement Task XVII on the "Integration of Demand Side Management, Energy Efficiency, Distributed Generation and Renewable Energy Sources".

## 5 Working Groups

Three working groups - Technology (Chair: Andreas Lugmaier), Modelling (Chair: Albrecht Reuter) and Policy (Chair: Rainer Bacher) - addressed the definition of a possible new Annex in terms of priorities and themes. The essence of these individual reports is captured in table 5.1.

**Table 5.1:** Summary of Feedback from Working Groups

Technology	Modelling	Policy
<ul style="list-style-type: none"> <li>ICT (requirements, cost, implications);</li> <li>Network operation guidelines (structure/design);</li> <li>Benchmarking of demonstrations and implementations;</li> <li>“how to” guidelines;</li> <li>Pursuit of logical progression:</li> </ul> <p>Learning ↓ Gap analysis ↓ Roadmap development ↓ Development of guidelines</p>	<ul style="list-style-type: none"> <li>Accommodation of other utility services and interfaces (eg thermal aspects);</li> <li>NIAM* development;</li> <li>Progression from deterministic to stochastic modelling;</li> <li>Identification/collation of source data for extensive DG populations</li> </ul> <p>*NIAM:- Network Impact Assessment Model</p>	<ul style="list-style-type: none"> <li>Definition of time horizons;</li> <li>Commentary and review of business interfaces (although accepting that much of the work could be performed in an economic and regulatory Annex);</li> <li>Geographical horizons and cross-border issues</li> </ul>

## 6 Workshop Outputs

It was agreed that there was a firm basis for the development of a future work programme activity, to be performed within a follow-on ENARD Annex, addressing “DG System Integration”.

### Considerations in the Development of a new Annex

Pertinent considerations for the development of such a new Annex include:

- The setting of clearly defined objectives;
- The Annex should appeal to and be of real value to member Governments;
- It should be realistically deliverable on a relatively short time horizon (2-3 years);

- It should be affordable; and
- It should complement other activities.

### Aim and Objectives of the Proposed New Annex II “DG System Integration”

The aim of the proposed new Annex is the development of guidelines and benchmarks to cover all the aspects of DG integration and, specifically, addressing the following facets:

- Technical/market/regulatory issues;
- Cross-boundary issues (market/technical/regional);
- Horizontal/cross-cutting theme;
- Drawing out the key lessons learnt (both positive and negative);
- The identification of modeling tools/limitations;
- The incorporation of a complementary foresighting subtask (eg addressing plug hybrids);
- The proactive engagement with related Implementing Agreements
- A proactive role for the Operating Agent;
- The extension of the net to cover significant non-member case studies;
- The clear identification of needs and requirements.

### Deliverables and Outputs

Anticipated deliverables and outputs from Annex II are expected to include:

- Detailed in-country surveys of current state-of-the-art, lessons learnt, limitations, future developments;
- Complementary foresighting activities and abstraction of visions/goals for the future (eg growth of future fully integrated active networks);
- Compilation of international overview report drawing out key messages;
- Formulation of guidelines document to assist Governments and DNOs to progress from passive to active networks;
- Identification of requirements and needs for future work.

ENARD, the IEA Implementing Agreement on Electricity Networks Analysis, Research and Development, functions within a framework created by the International Energy Agency (IEA). The views, findings and publications of ENARD do not necessarily represent the views or policies of the IEA Secretariat or of all its individual member countries.

### ENARD Participating Countries:

Austria Belgium Denmark Finland Italy Netherlands Norway Spain Sweden Switzerland UK